

Risk based design of hydraulic structures

Fault Tree Workshop

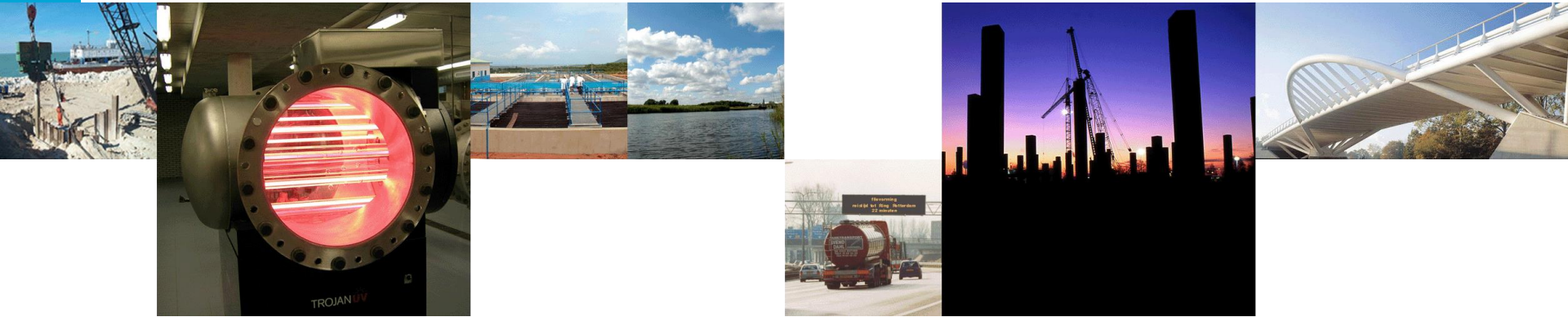

In cooperation with





Aalberts, Verheijen, Le
Lanzafame, Jonkman, Breedveld, and Co.

System reliability – Fault trees

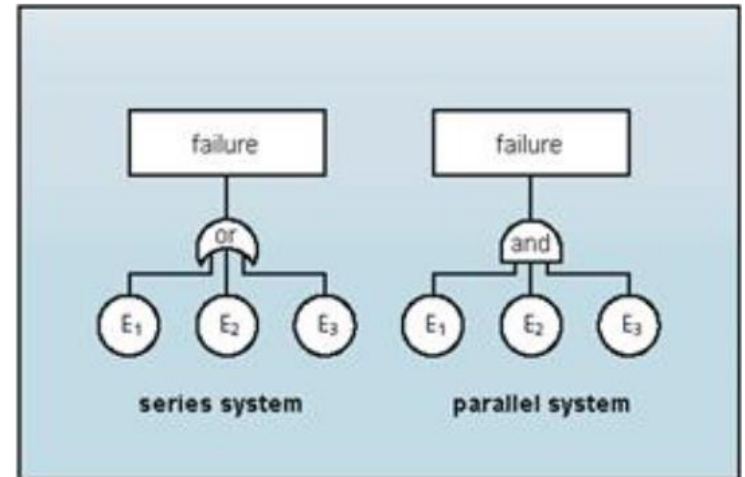
- Graphical method for evaluating system failure probability
- CIE4130 Lecture notes Chapter 9



$P_{f,system}$ (with n components):

system	gate	operator	components		
			mutually exclusive	independent	fully dependent
series	 OR	\cup	$\sum_{i=1}^n P_i$ (upper bound)	$1 - \prod_{i=1}^n (1 - P_i)$	$\max\{P_i\}$ (lower bound)
parallel	 AND	\cap	0 (lower bound)	$\prod_{i=1}^n P_i$	$\min\{P_i\}$ (upper bound)

Overview of fault tree workshop

- Introduction to case study
- Work on assignment in groups of 4-5
- Presentation by groups and discussion
- Wrap-up and conclusions

Afsluitdijk and IJsselmeer

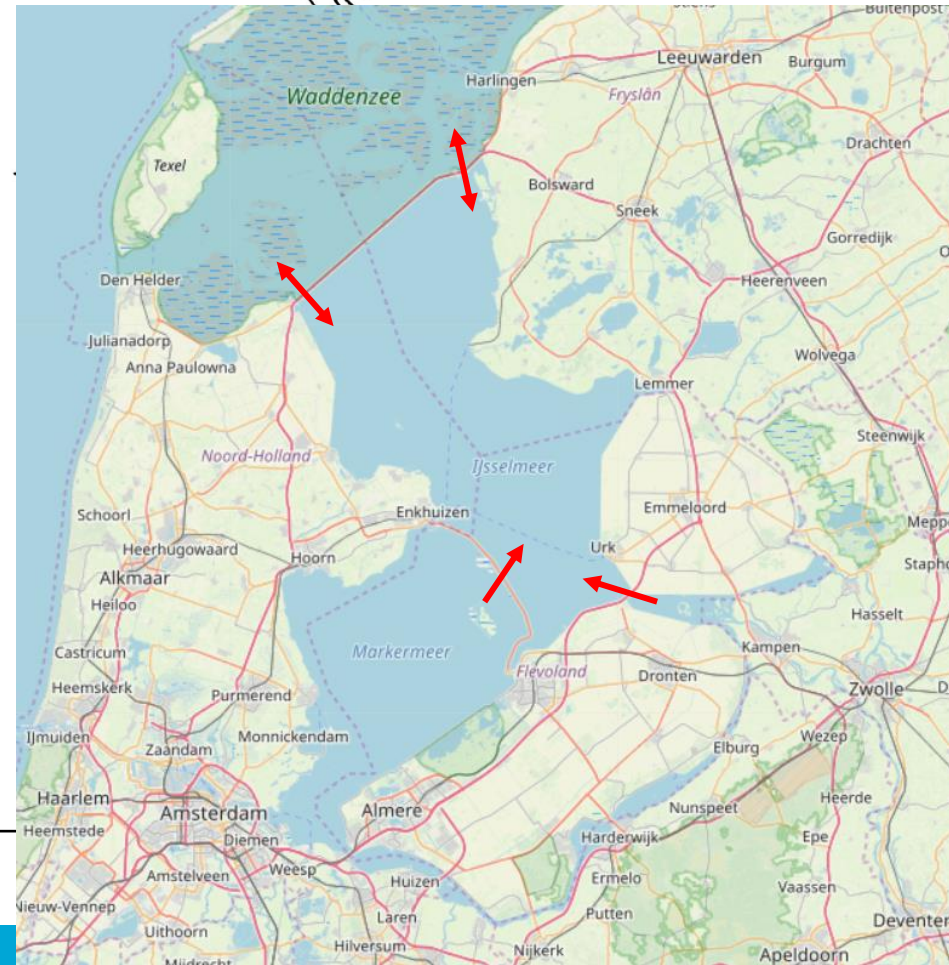
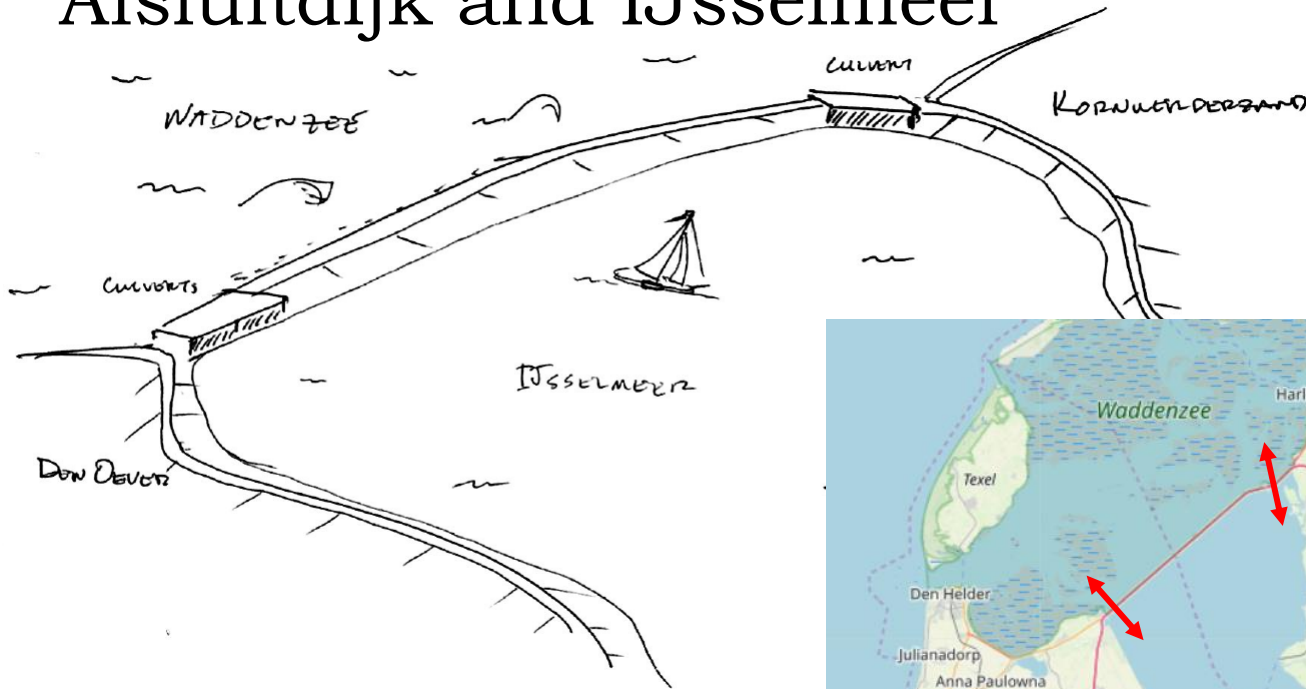

Afsluitdijk inlet/outlet culverts



Culverts close to limit IJsselmeer level

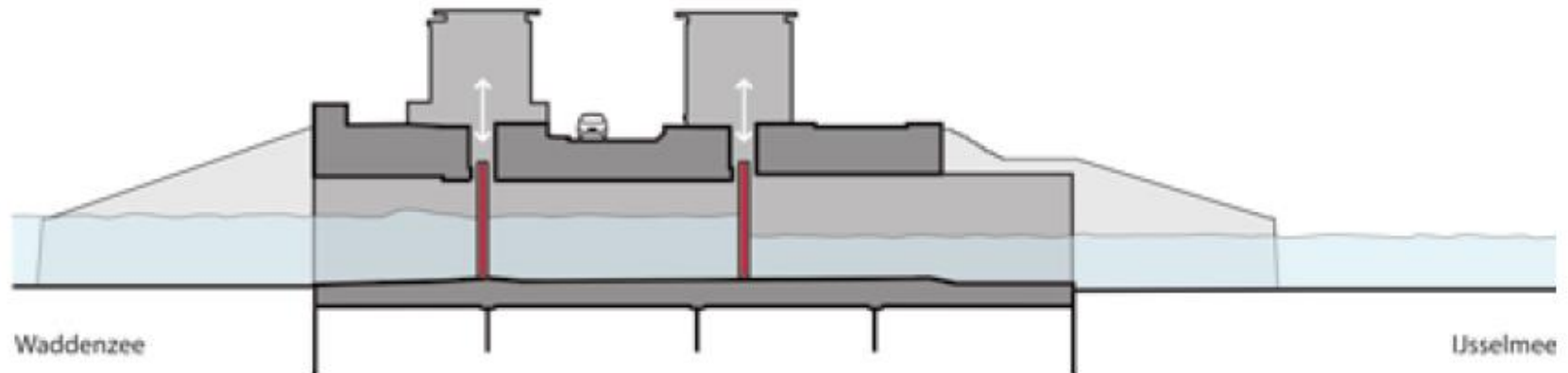

Normal operation:

- prevent water from Waddenzee entering IJsselmeer

Failure:

- Culvert does not close when asked, *and*
- Water flow into IJsselmeer exceeds critical amount

$$P_{f,system} = P(nc) \cdot P(Q > Q_{max} | nc)$$

Derivation of norm for the Afsluitdijk

- Maximum allowable failure probability = $1/3000 = 0.00033$
- Non-closure failure mechanism portion = 0.04
- Norm =
 $0.04 * 0.00033 = 1.3e-5$

$$P_{f,system} < 1.3e^{-5}$$



System failure (critical hydraulic conditions)

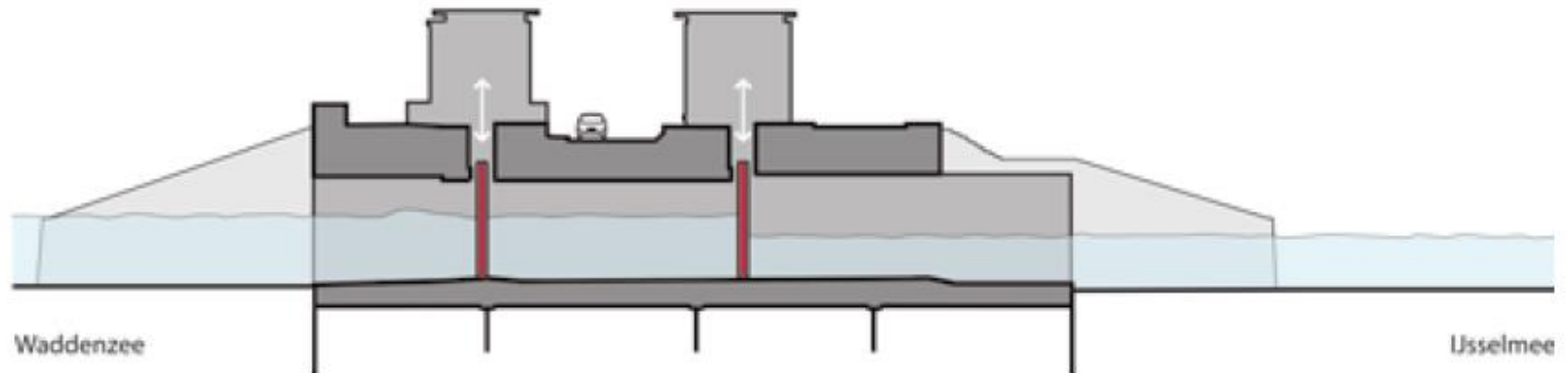

Governed by:

1. Critical hydraulic conditions in IJsselmeer and Waddenzee
2. Number of open culverts, i (non-closure, nc)



1. Critical hydraulic conditions

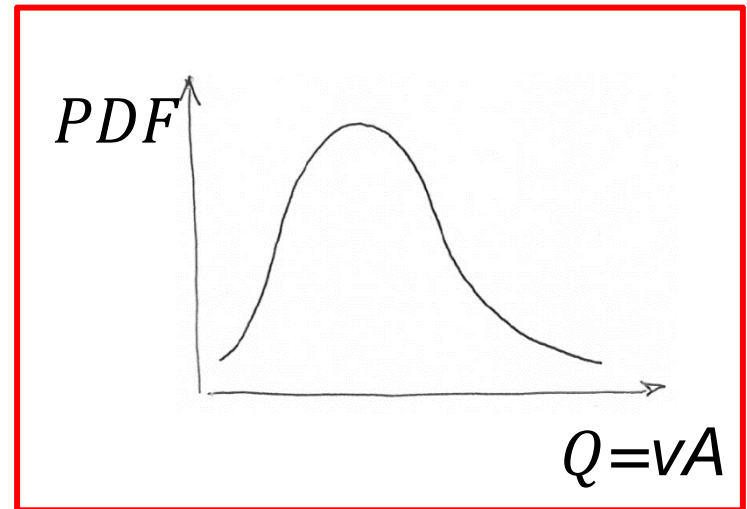
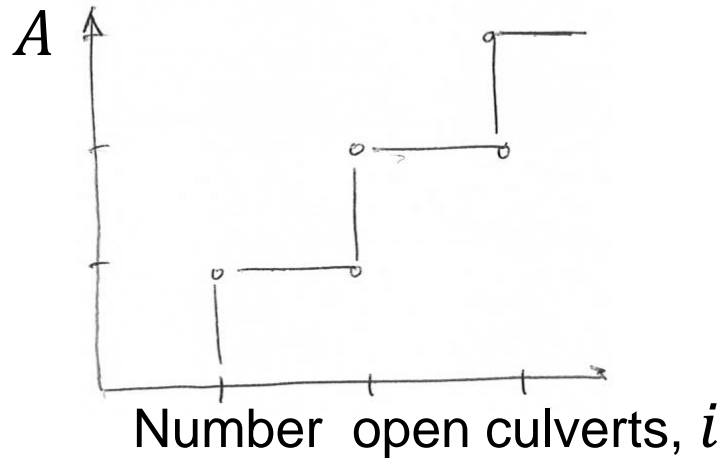
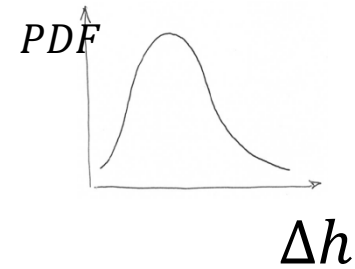
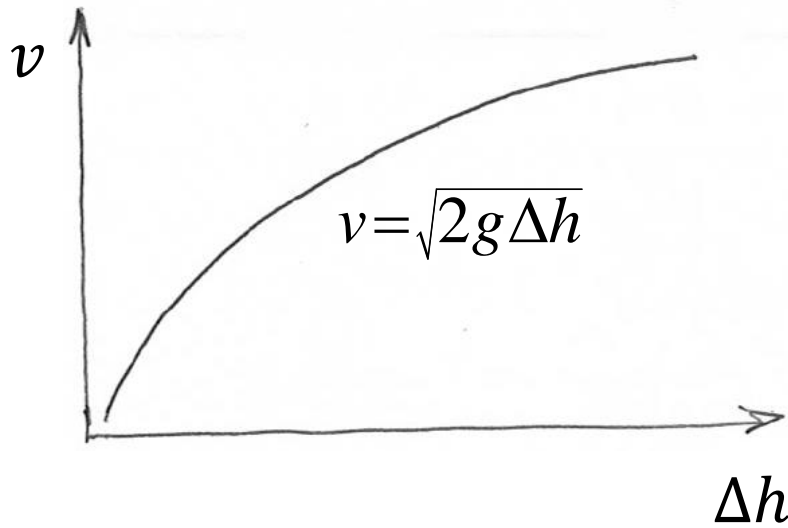

1. Critical hydraulic conditions

- 3 cases of non-closure
- Sum all scenarios (OR case)

Number of open culverts, i	$P(Q > Q_{\max})$
1	6.39 E-3
2	3.27 E-2
3	1.89 E-1

$$P_{f,system} = \sum_{i=1,2,3} P_{nc,i} \cdot P(Q < Q_{\max,i}) < 1.3e^{-5}$$

1. Critical hydraulic conditions

Hint: top level of fault tree

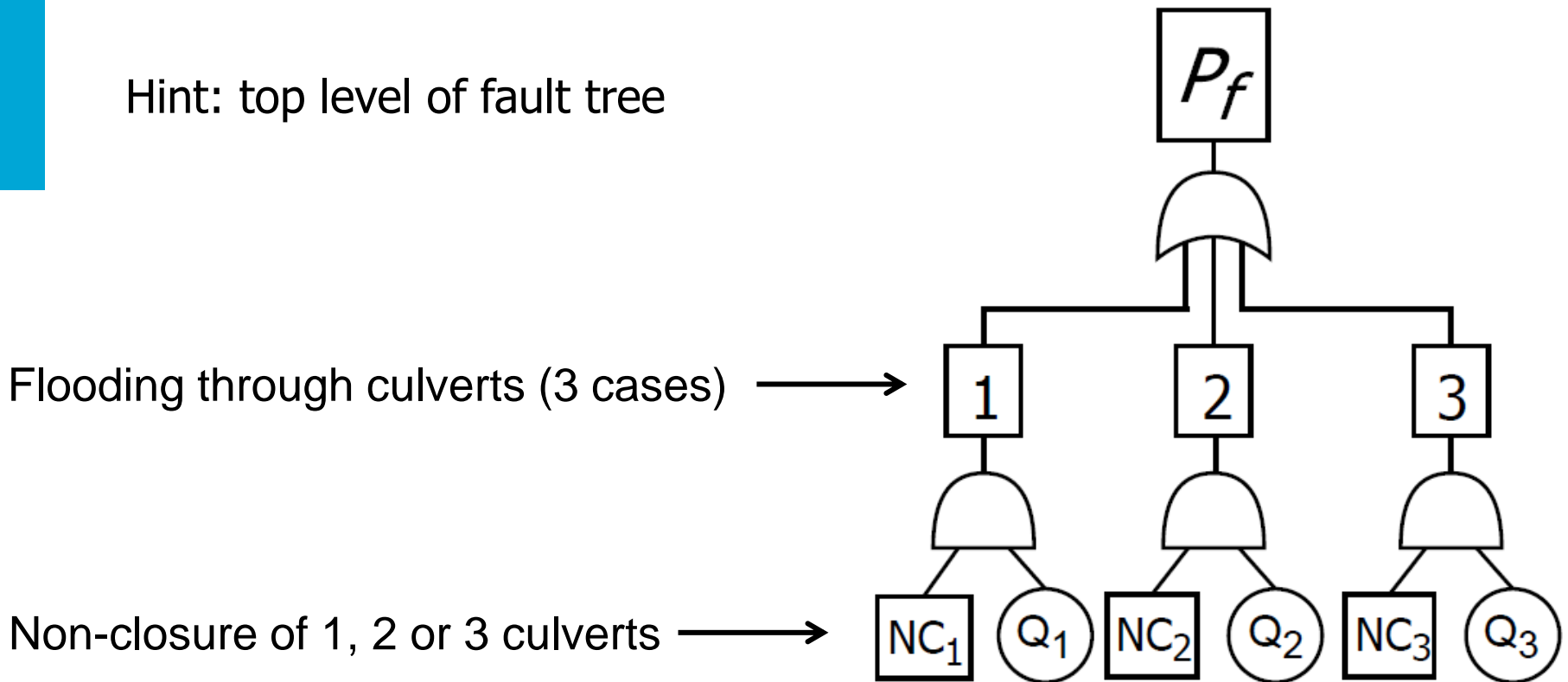

$$P_{f,system} = \sum_{i=1,2,3} P_{nc,i} \cdot P(Q < Q_{max,i}) < 1.3e^{-5}$$

Probability of 1, 2 or 3 non-closures, $P_{nc,i}$

- All 3 culverts are always asked to close together ($n=3$)
- Bernoulli: probability of i failures in n trials
- Need probability of single culvert non-closure, P_{nc}

$$P_i = \frac{n!}{i!(n-i)!} * p^i * (1-p)^{(n-i)}$$

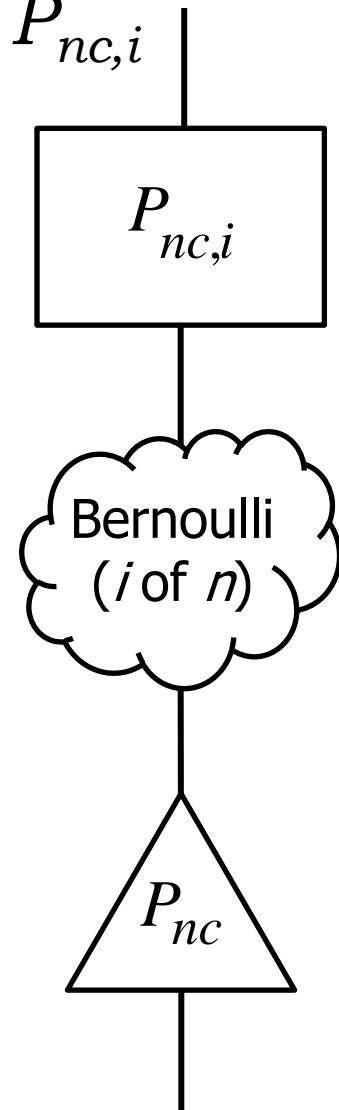

Single culvert non-closure, P_{nc}

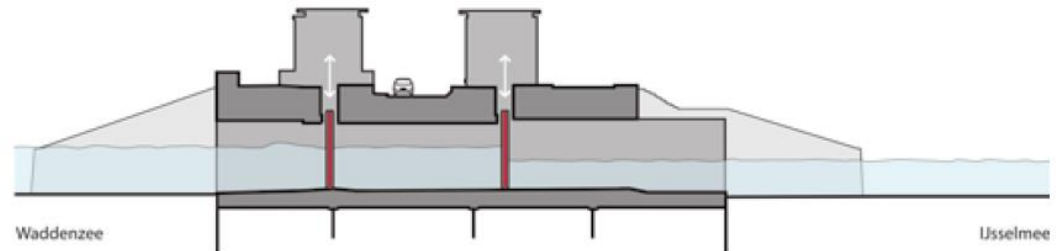

- System contains: 3 culverts, each with 2 gates
- Failure modes:
 - Gates can jam
 - Culvert fails due to a construction problem
 - Electrical and control system between components
 - Human error (causes all 3 culverts to stay open)

Electricity and control system

- Component levels: primary, culvert, gate
- Electricity connection to each level (E_p E_c E_g)
- Closure signal sent/received each level (C_p C_c C_g)
- Each component is independent

→ Electricity

---●--- Control

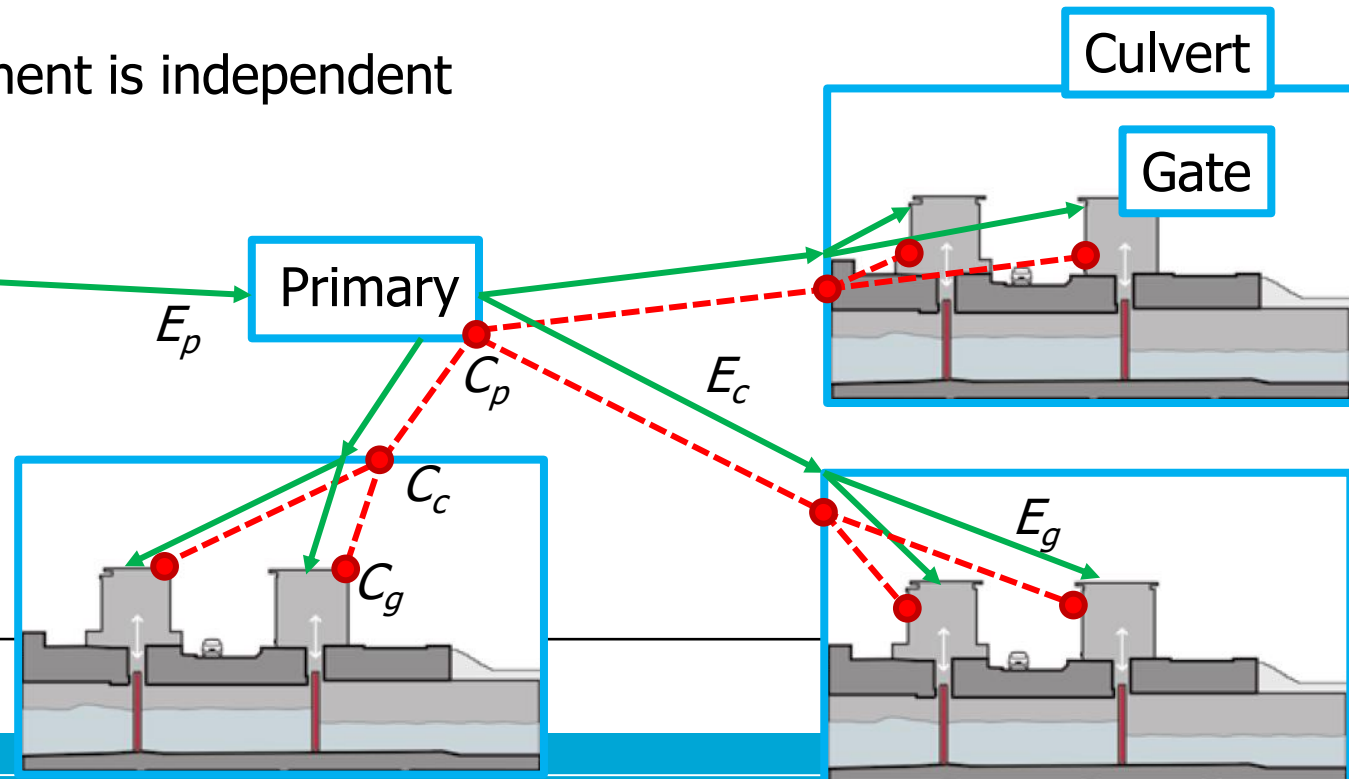

Failure modes and probability for fault tree

Symbol	Component	Consequence	Probability
C_p	Primary control system	All culverts open	3.5E-05
E_p	Primary electrical supply	All culverts open	7.3E-05
C_c	Culvert control system	Culvert open	3.8E-04
E_c	Culvert electrical supply	Culvert open	9.6E-06
C_g	Gate control system	Gate open	8.7E-06
E_g	Gate electrical supply	Gate open	1.5E-04
CC	Construction failure of culvert	Culvert open	2.0E-09
HE	Human error	All culverts open	2.5E-06
J_g	Jammed gate	Gate open	2.4E-03

Assignment – 1. System failure

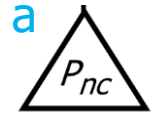

1. Find probability of culvert system failure $P_{f,system}$

a. Fault tree for single culvert non-closure, P_{nc}

b. Evaluate $P_{nc,i}$ for i non-closure cases using Bernoulli

c. Fault tree for $P_{f,system}$ that includes 3 non-closure cases

Evaluate: does the system meet the requirement?

Remember to use all events from the table

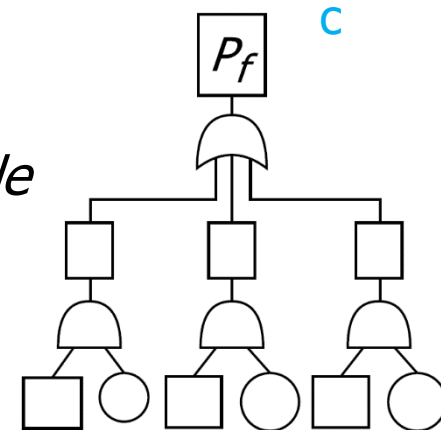
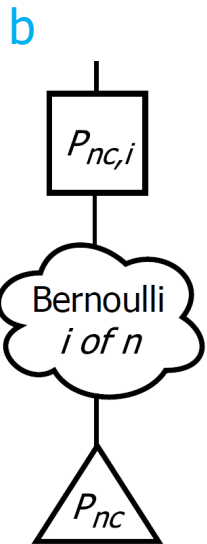

Assignment – 2. Design optimization (if time)

What part of the fault tree influences system failure the most?

- Get as close to norm as possible (but still below) while minimizing the expected projects costs

- “Investment points” = proxy for costs

Design option	Points
At gate level	1
At culvert level	3
At central level	5
Extra gate construction	5
Removing second gate	-5

Rules for optimization:

- Don't introduce new components
- Add or remove redundancy within the existing system
- Keep the numbers of culvert at 3

Assignment

1. Find probability of culvert system failure $P_{f,system}$
2. Optimize design (if time allows)

Form groups of 4-5, prepare fault tree and results for discussion

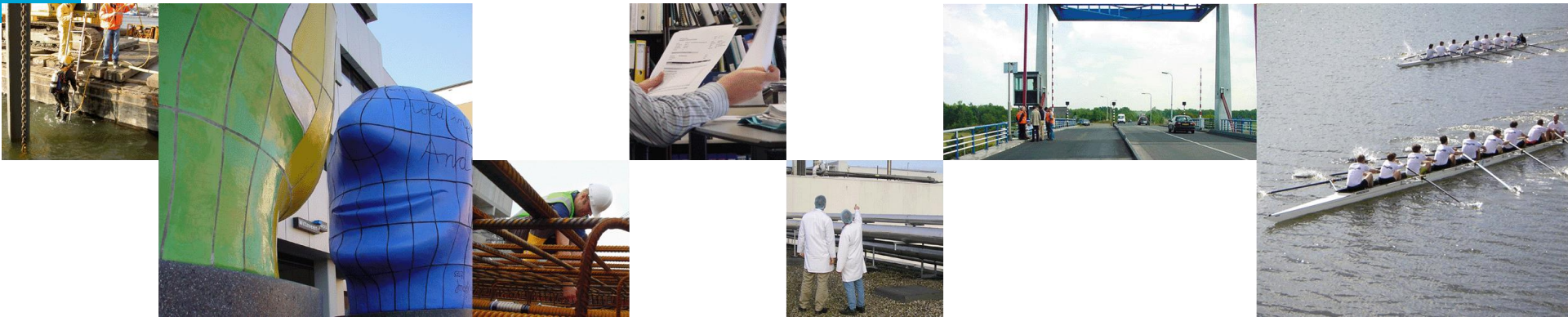

Documents (see course website Workshop 4):

- Fault tree workshop introduction (these slides)
- Fault tree workshop handout
- Calculation template (online Google sheet or Python code)
- Fault tree diagram template (optional, also online Google sheet)



Case study results

$P_{f,system}$ (with n components):

system	gate	operator	components		
			mutually exclusive	independent	fully dependent
series	 OR	\cup	$\sum_{i=1}^n P_i$ (upper bound)	$1 - \prod_{i=1}^n (1 - P_i)$	$\max\{P_i\}$ (lower bound)
parallel	 AND	\cap	0 (lower bound)	$\prod_{i=1}^n P_i$	$\min\{P_i\}$ (upper bound)

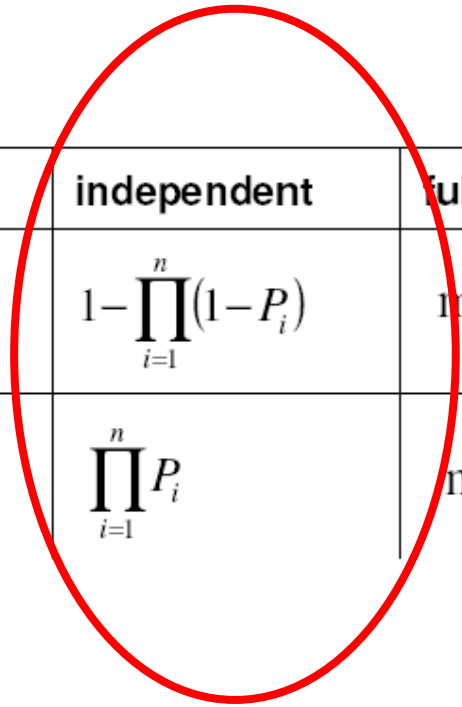

Culvert system failure
 $P_{f,system}$

$2.9e-5 (> 1,3e-5)$

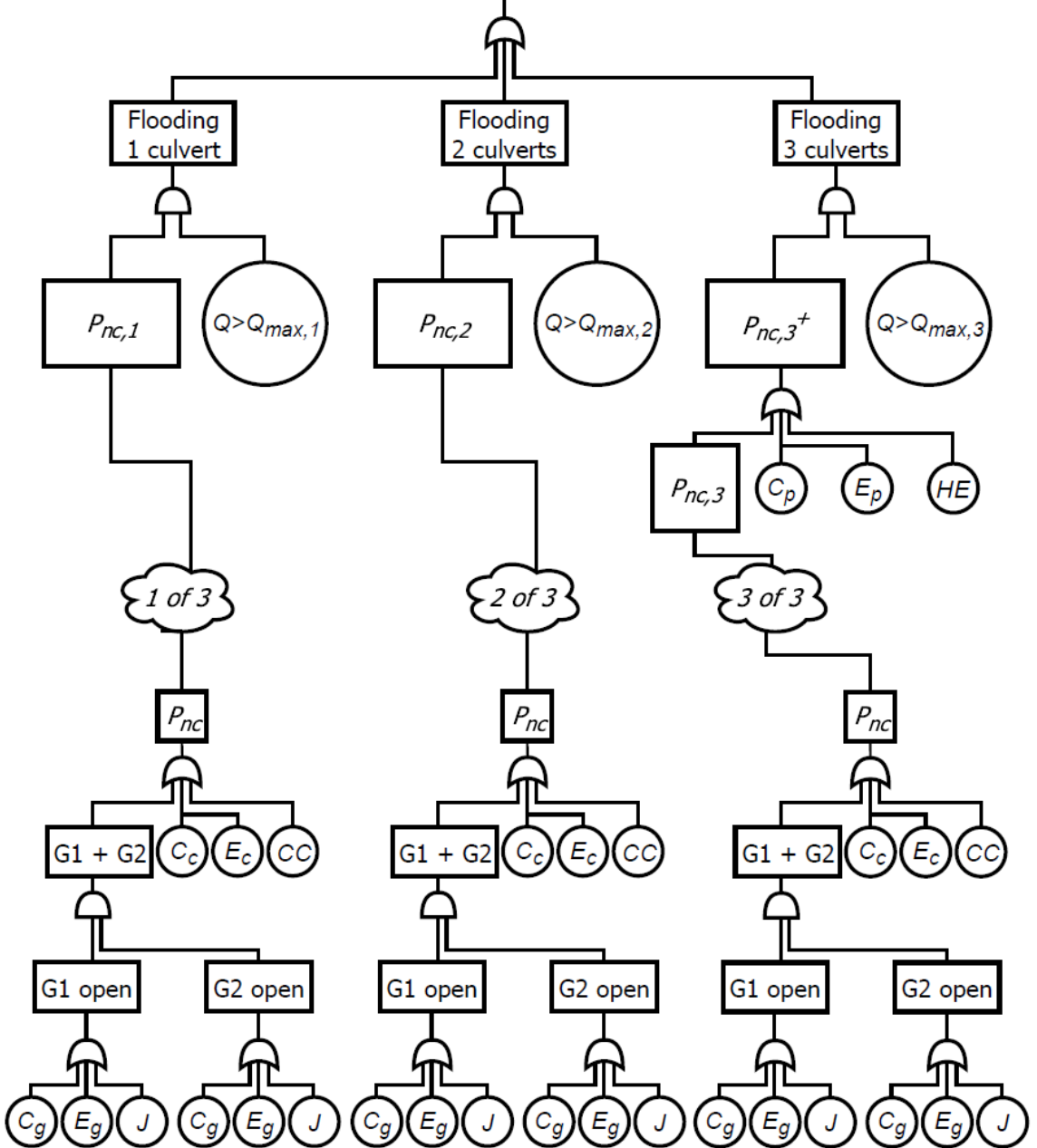

1a. Single culvert non-closure

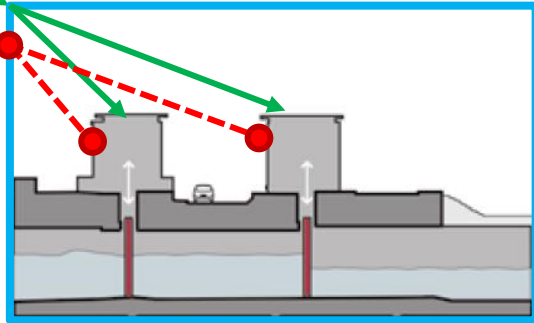

→ Electricity

- - - ● Control

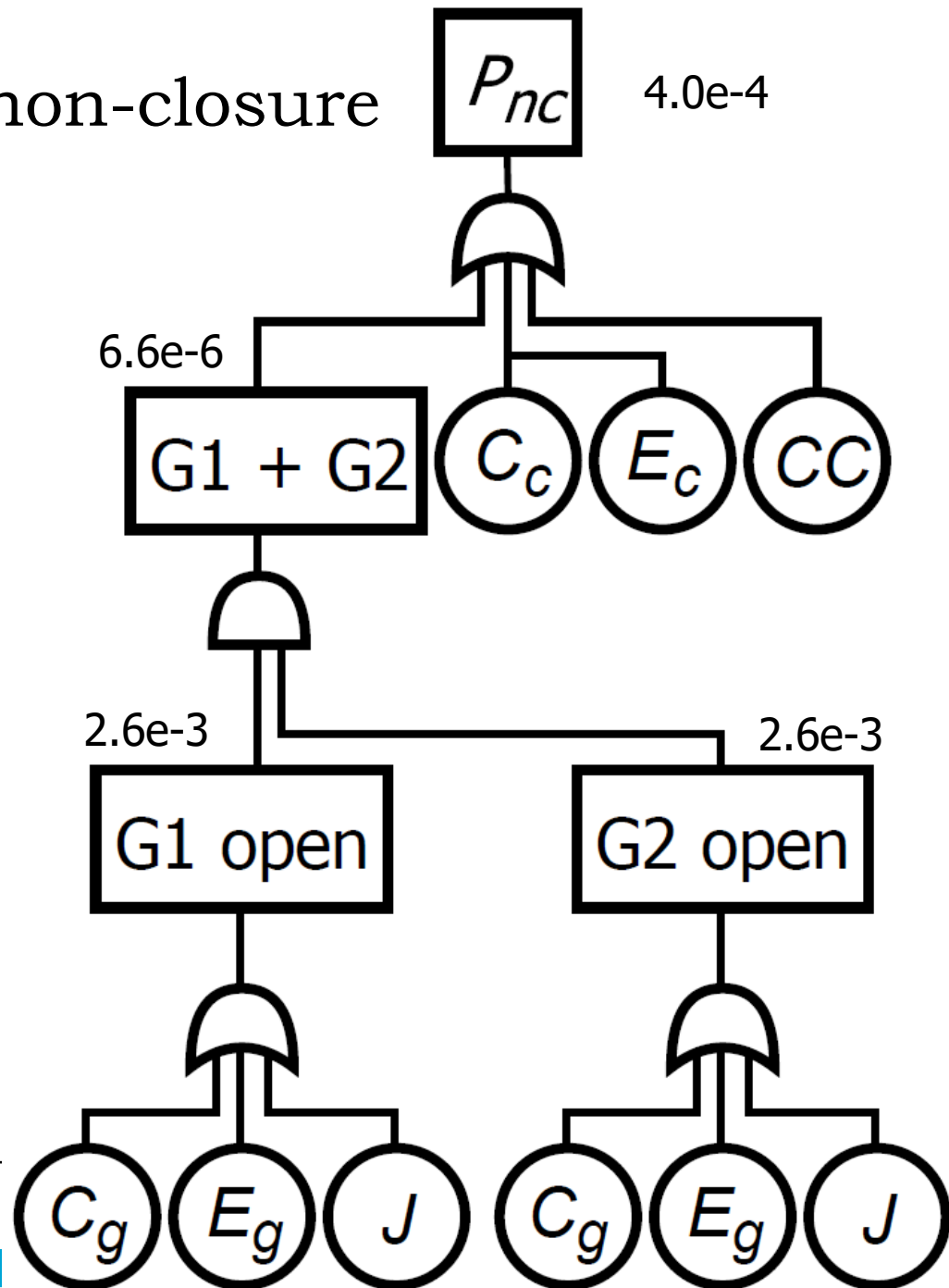

1a. Single culvert non-closure

C_c	3.8E-04
E_c	9.6E-06
CC	2.0E-09

C_g	8.7E-06
E_g	1.5E-04
J	2.4E-03

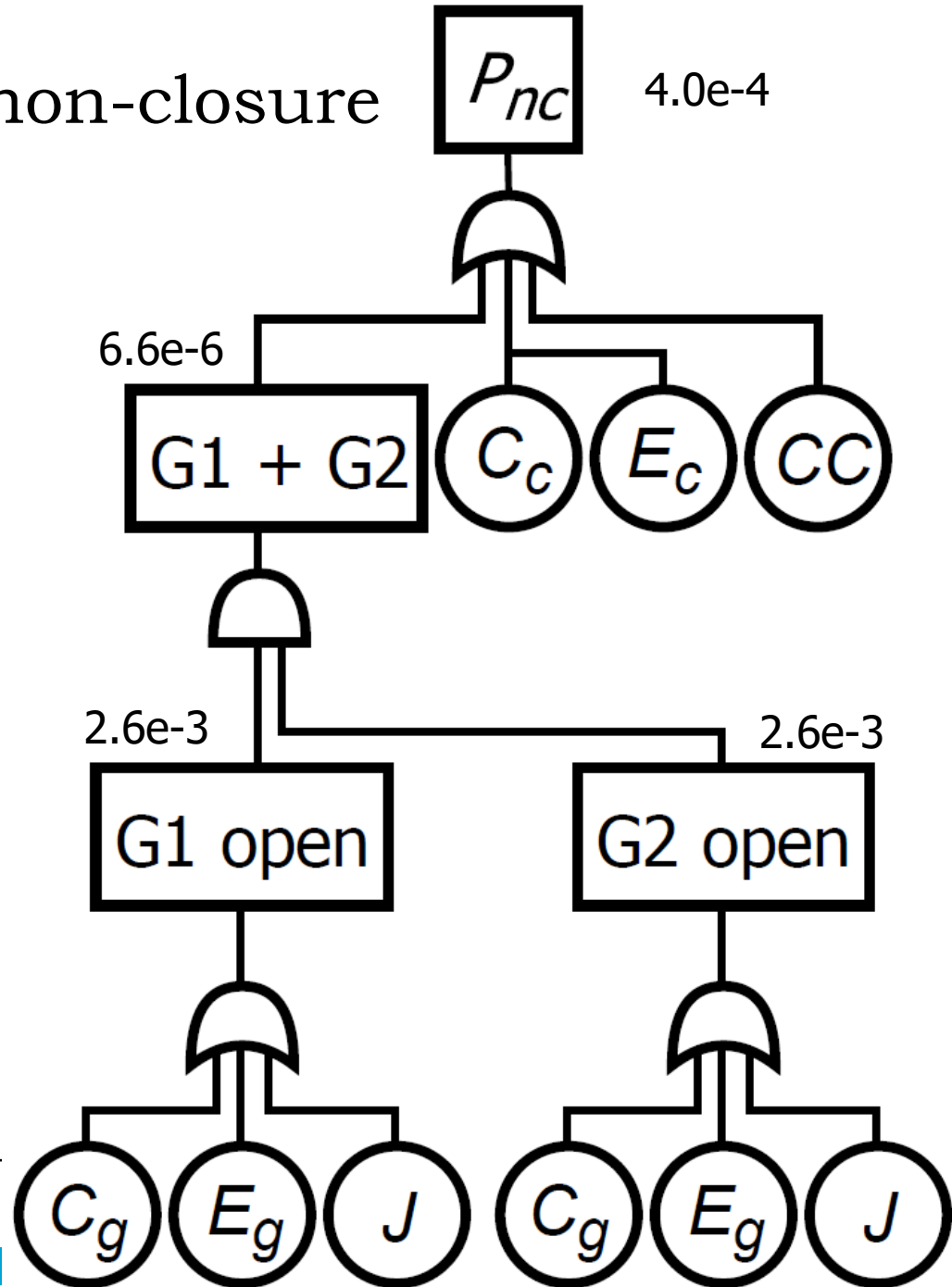

1b. Bernoulli

i non-closures out of n trials

i	$P_{nc,i}$
1	1.2E-03
2	4.7E-07
3	6.2E-11

$$P_i = \frac{n!}{i!(n-i)!} * p^i * (1-p)^{(n-i)}$$

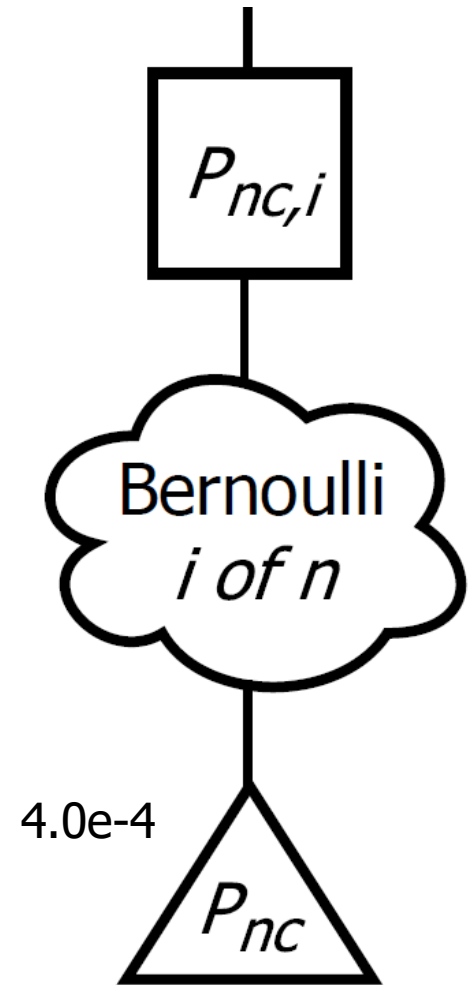

1c. System failure

1 non-closure out of 3 trials

i	$P(Q > Q_{max})$
1	6.39E-03
2	3.7E-02
3	1.89E-01

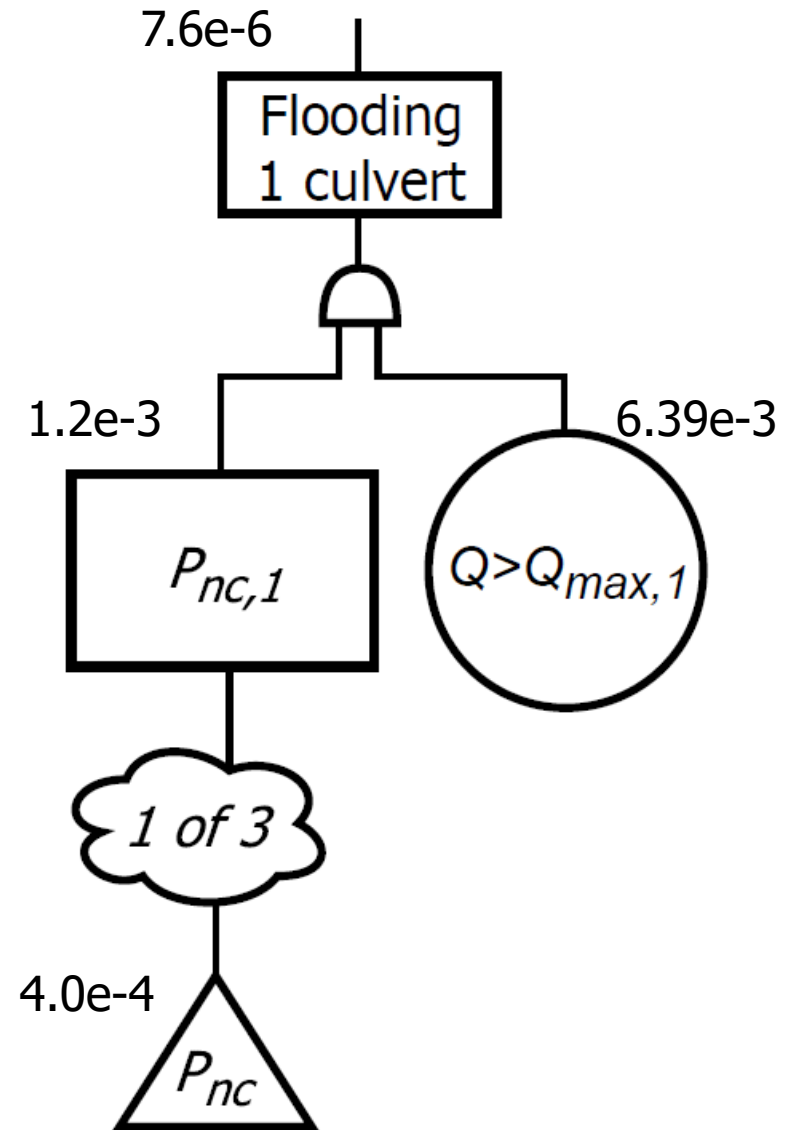

1c. System failure

3 non-closures out of 3 trials

C_p	3.5E-05
E_p	7.3E-05
HE	2.5E-06
	$\Sigma = 1.1E-04$

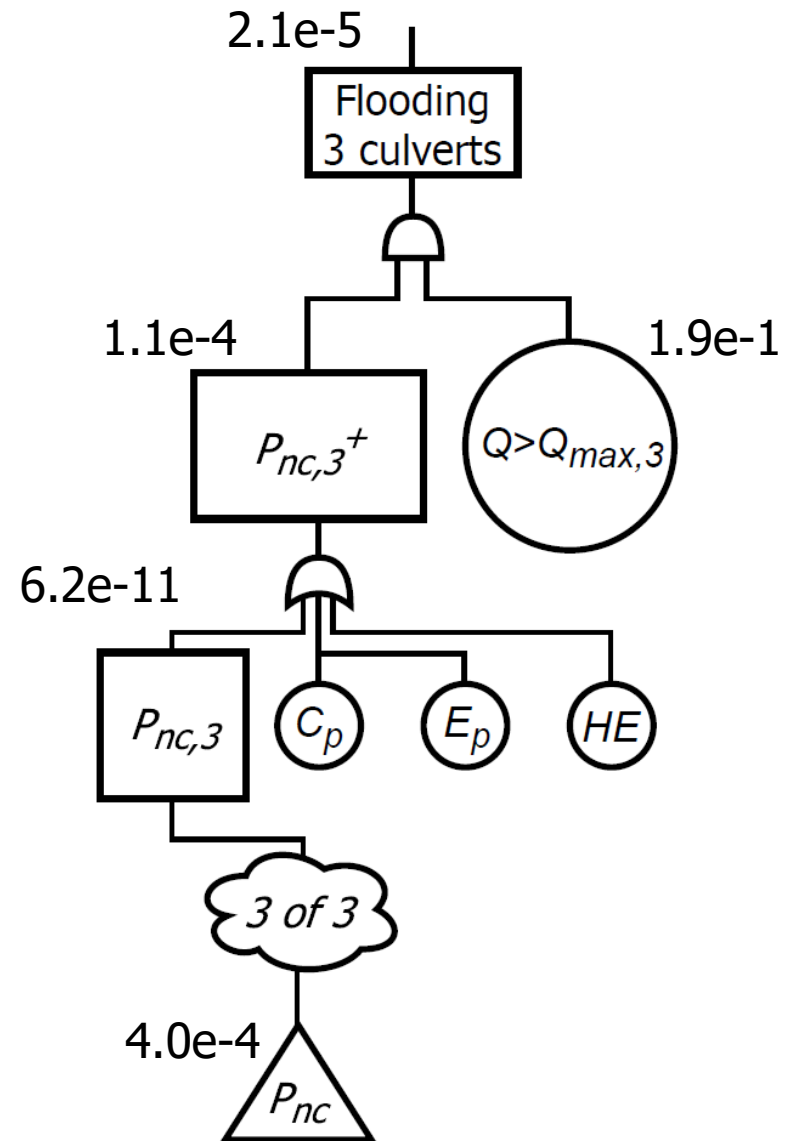

1c. System failure

All 3 non-closures

i	$P_{nc,i}$	$P(Q > Q_{max,i})$	$P_f(\text{flood} i)$
1	1.2×10^{-3}	6.4×10^{-3}	7.6×10^{-6}
2	4.7×10^{-7}	3.3×10^{-2}	1.5×10^{-8}
3	$1.1 \times 10^{-4} *$	1.9×10^{-1}	2.1×10^{-5}
			$\Sigma = 2.9 \times 10^{-5}$

*includes other failure modes for $i=3$

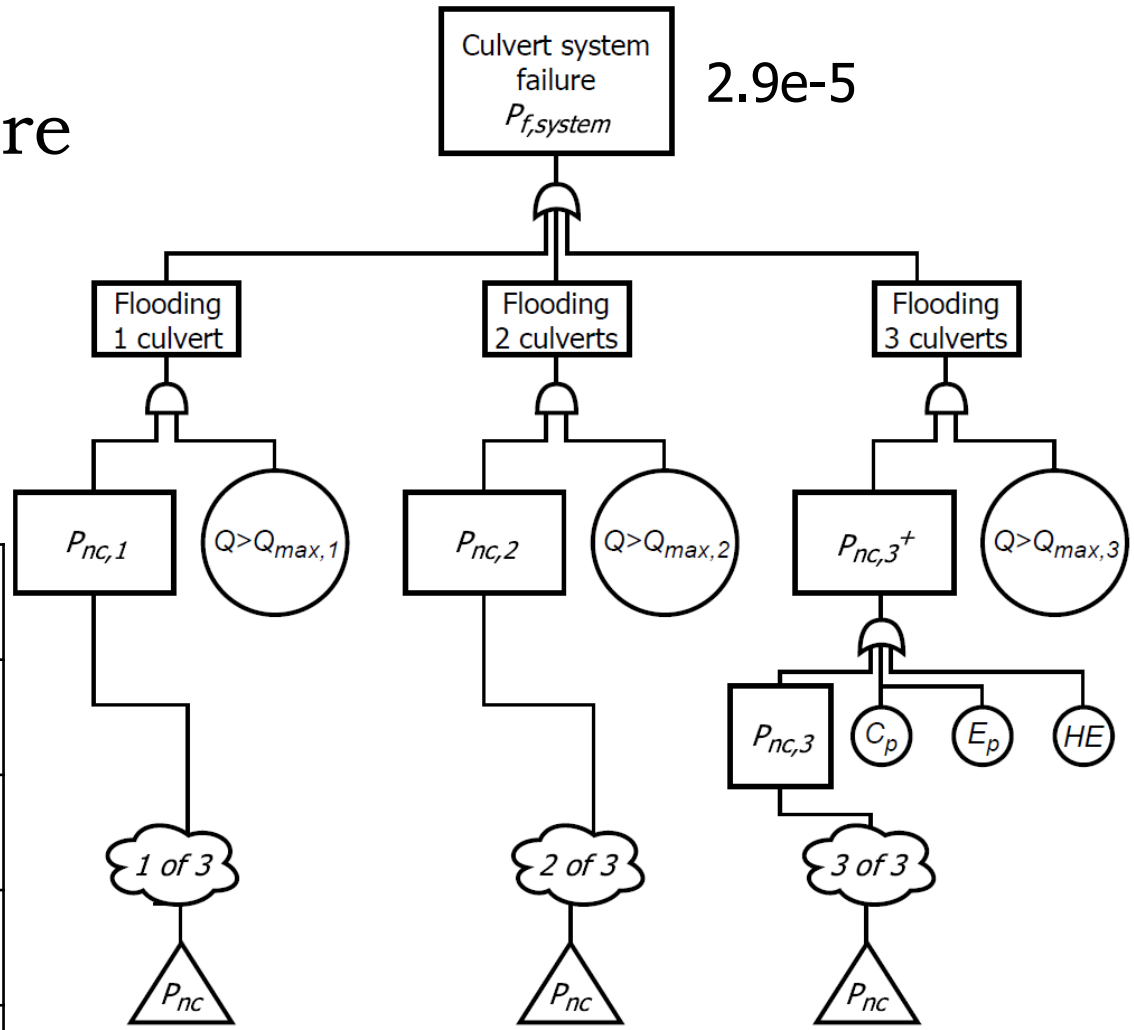

1a. Single non-closure – 2 approaches

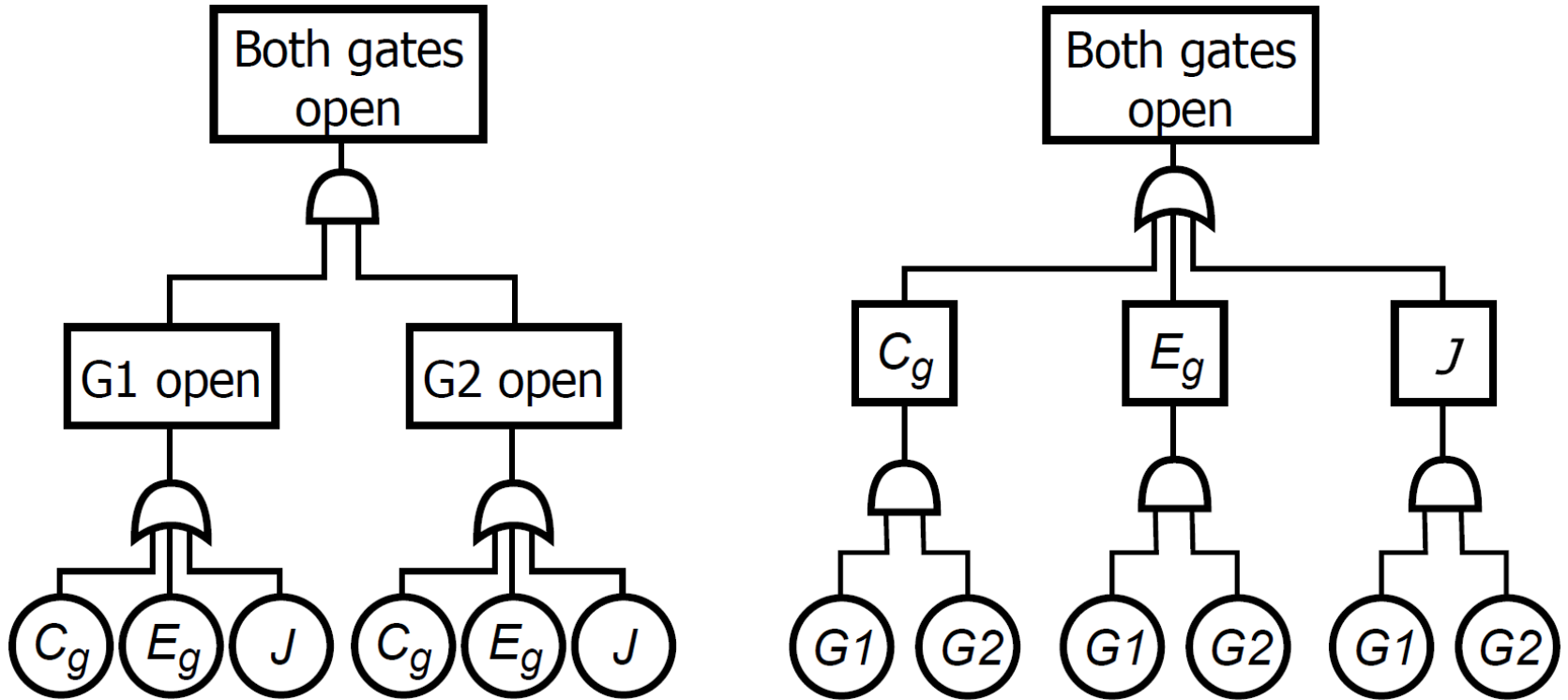

1a. Single non-closure – approach 1

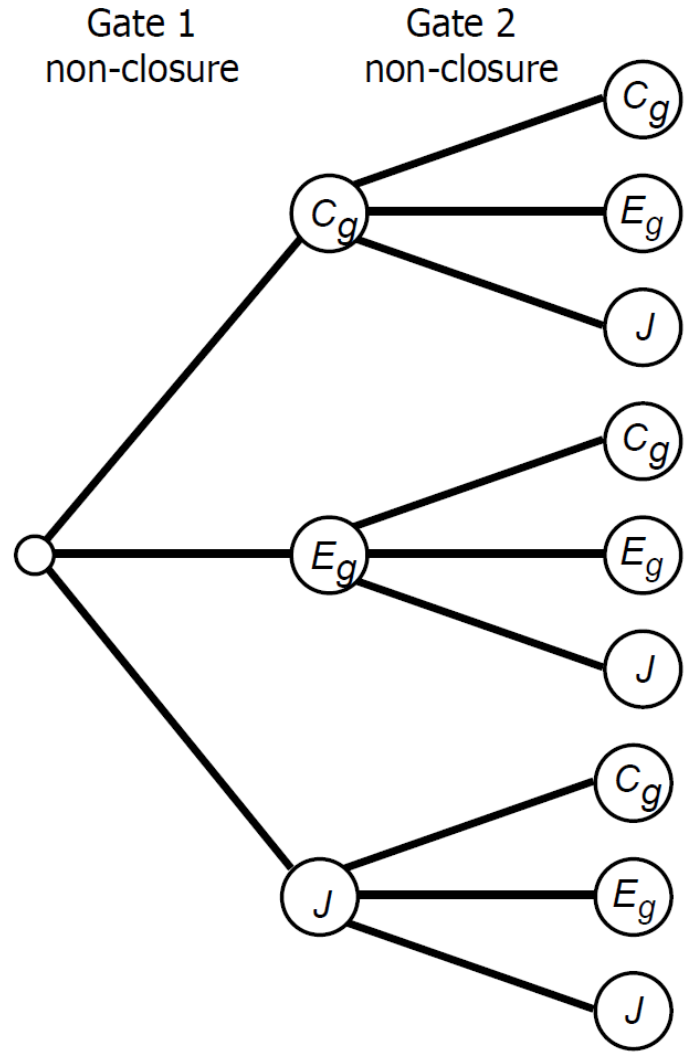
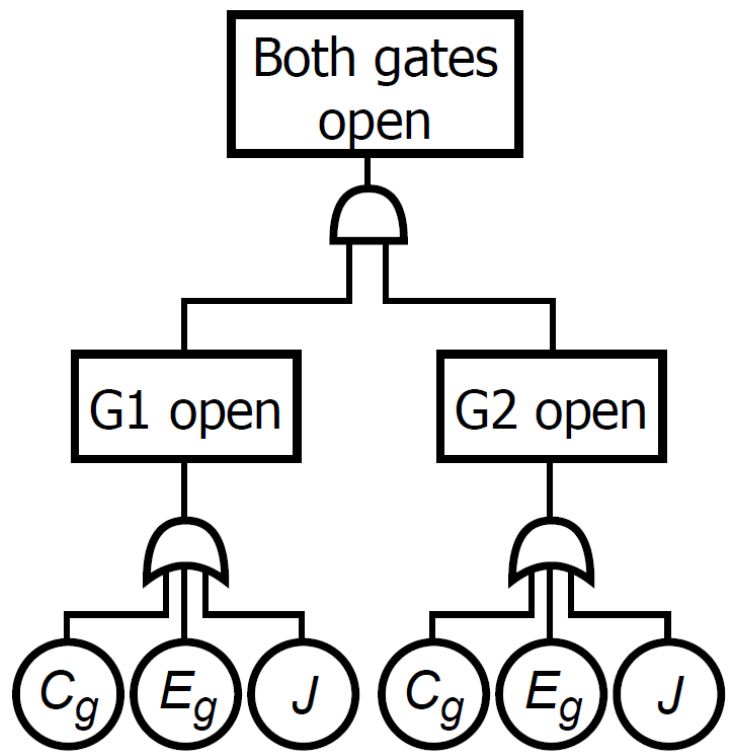

1a. Single non-closure – approach 2

2nd alternative does not consider all combinations!

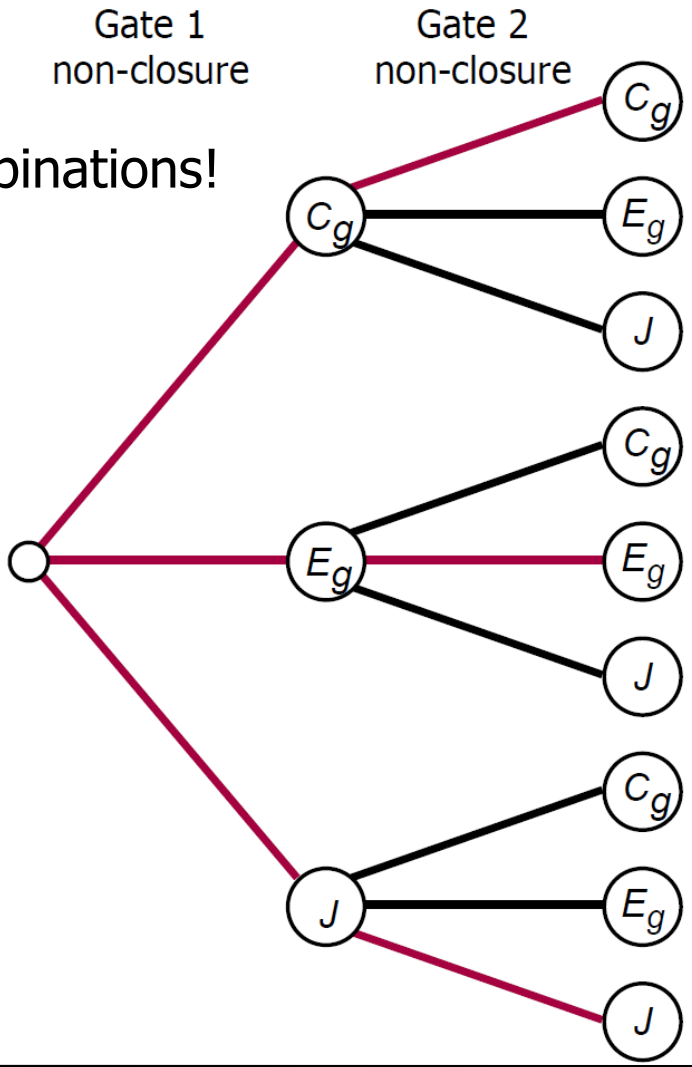
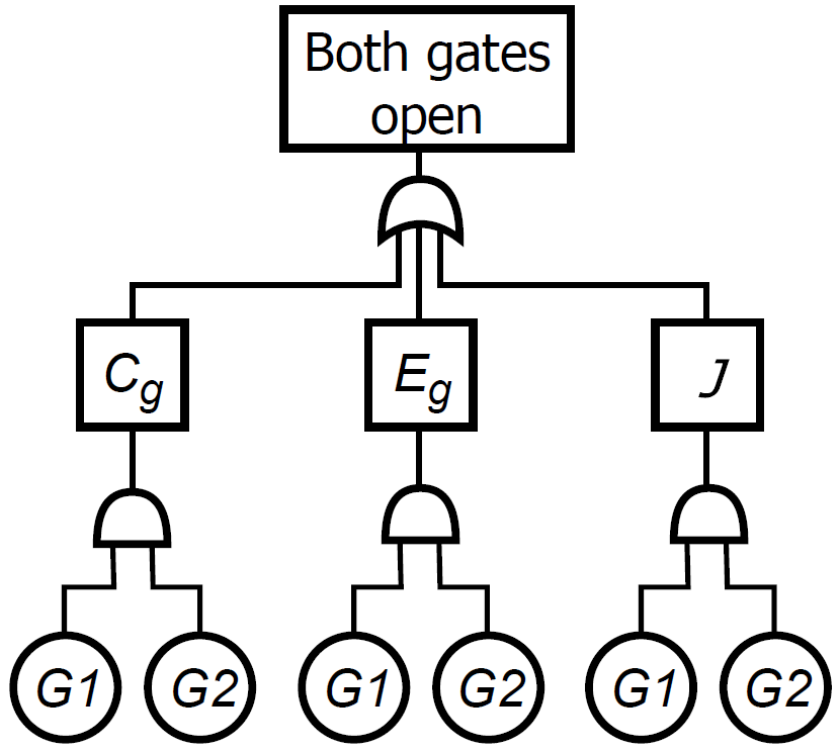

1a. Single non-closure – 2 approaches

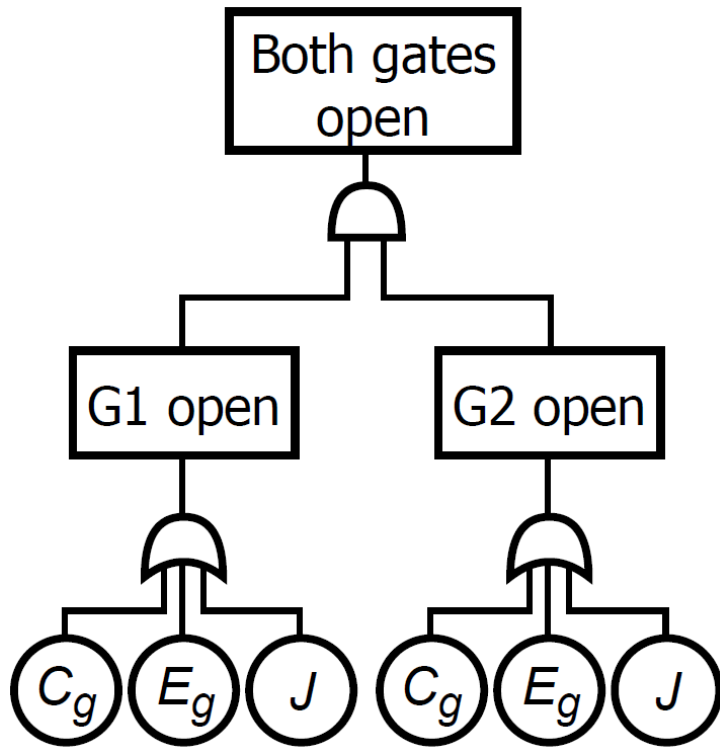

$$P = (P_1 + P_2 + P_3)^2$$

$$P = P_1^2 + P_2^2 + P_3^2 + 2(P_1 + P_2 + P_3)$$

$$P = 6.6e-06$$

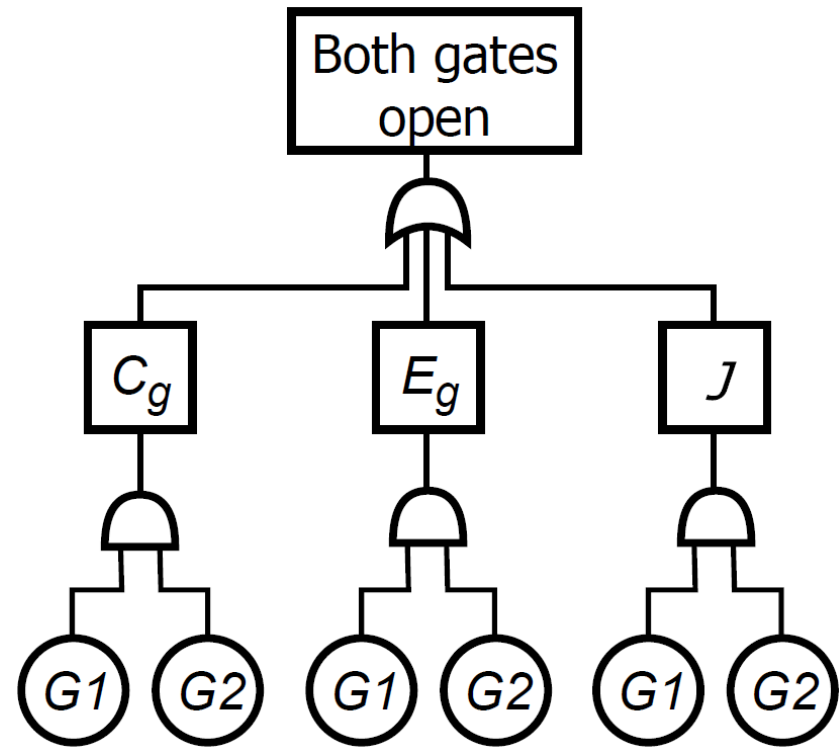

$$P = P_1^2 + P_2^2 + P_3^2$$

$$P = 5.8e-6$$

1a. Single non-closure – 2 approaches

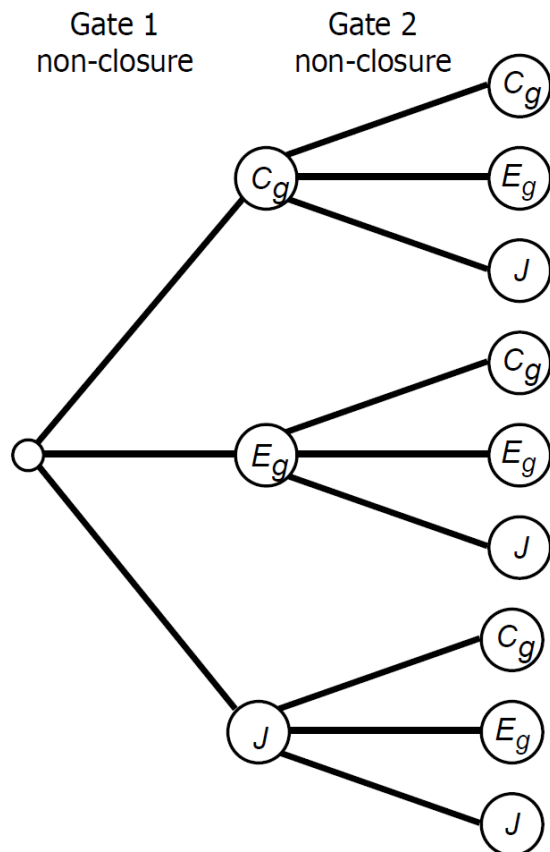

$$P = P_1 (P_1 + P_2 + P_3) + P_2 (P_1 + P_2 + P_3) + P_3 (P_1 + P_2 + P_3)$$

$$P = 6.6e-06$$

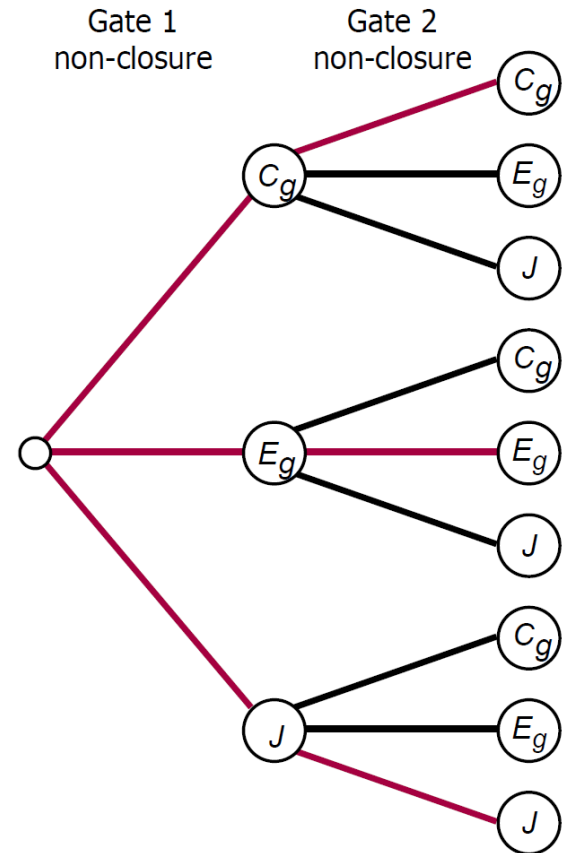

$$P = P_1^2 + P_2^2 + P_3^2$$

$$P = 5.8e-6$$

Design optimizations

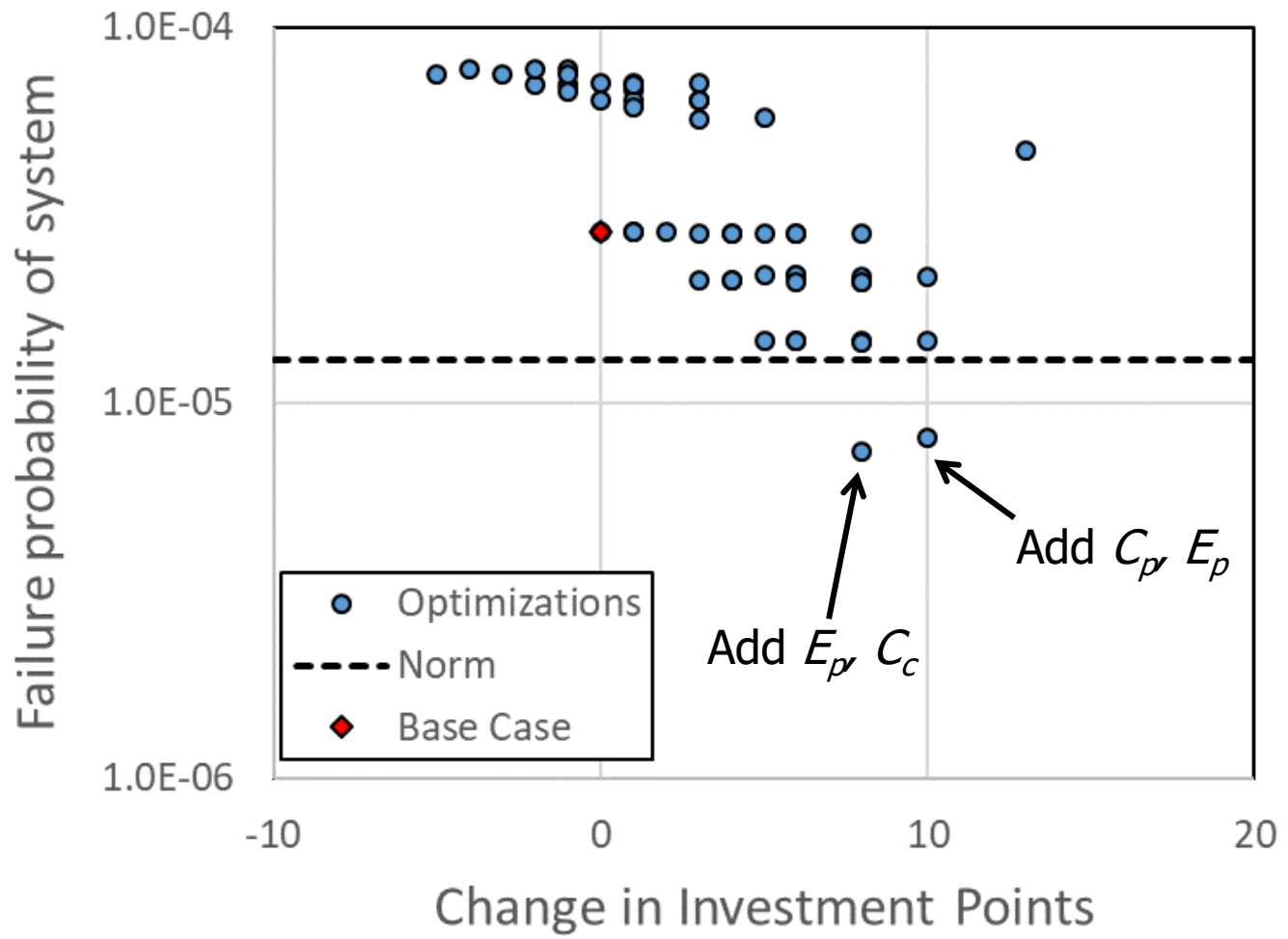

Project in reality

Influence 1 or 2 gates on:

- **safety;**
- initial and life time costs;
- maintenance ease;
- safety during maintenance;
- monumental significance of the Afsluitdijk.

Project in reality – optimize safety

Possible steps

- Start small (like we did)
- Scale up to the reality (15 culverts)
- Check out sensitivity (see screenshot for 3 culverts)
- Check conservatism in POF sensitive components
- For (in)sensitive components find alternatives (cheaper/safer) or add/remove redundancy (light weight cost optimization)

```
increasing Cp with factor 2 increases pof with 23 %  
increasing Ep with factor 2 increases pof with 48 %  
increasing Cc with factor 2 increases pof with 26 %  
increasing Ec with factor 2 increases pof with 1 %  
increasing Cg with factor 2 increases pof with 0 %  
increasing Eg with factor 2 increases pof with 0 %  
increasing CC with factor 2 increases pof with 0 %  
increasing HE with factor 2 increases pof with 2 %  
increasing J with factor 2 increases pof with 1 %
```